



ISO 9001:2015

INSTRUCTIONS DE MONTAGE

Ref. S19RS

Urinoir GOLEM avec rinçage automatique Version transformateur externe

Fonctions



Temps d'utilisation

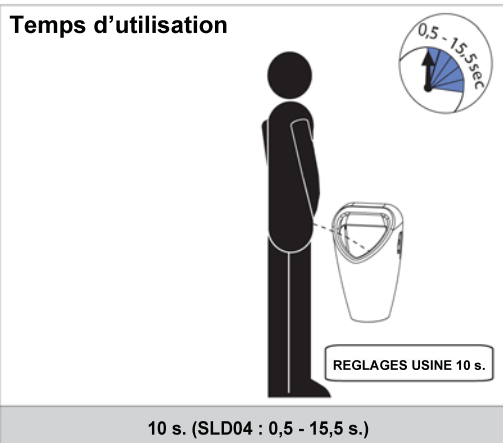

Temps de rinçage

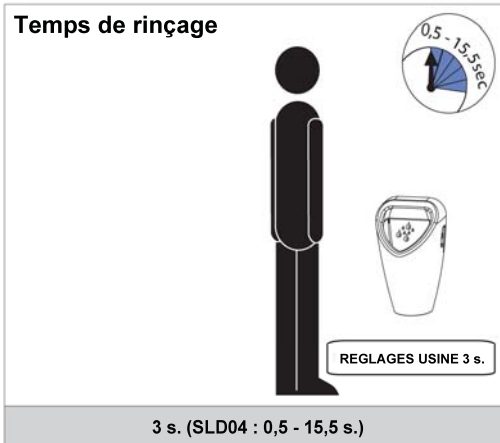

NOTICE DE MONTAGE

Equipements fournis

S19RS

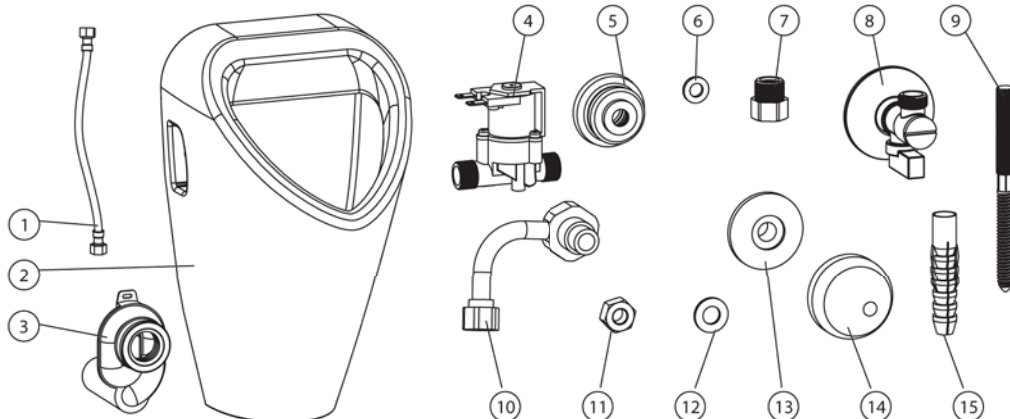

Número	Référence	Quantité
1	45995	1
2	45235	1
3	45252	1
4	45936	1
5	44743	1
6	47786	1
7	46480	1
8	45940	1
9	45259	2
10	44796	1
11	45259	2
12		2
13		2
14		2
15		2

Installation

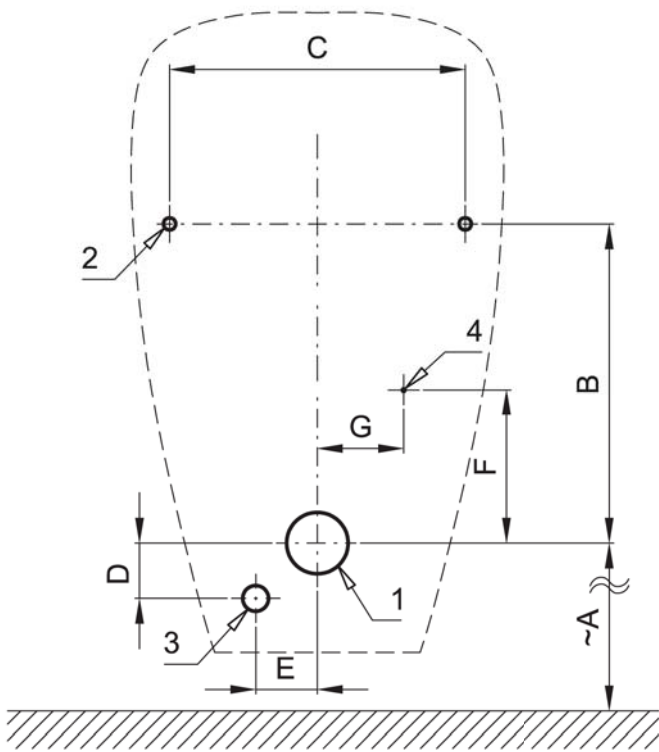

COTE [mm]	A	B	C	D	E	F	G	H	I	J	K	L
DIMENSIONS [mm]	400	260	240	45	50	125	70					

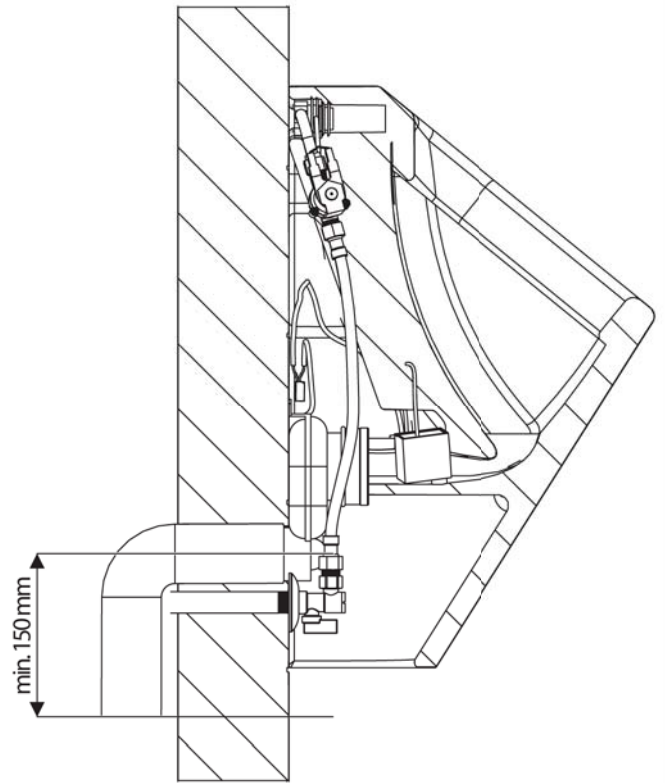

- 1 - Evacuation Ø 50 mm**
- 2 - Trous Ø 10 mm (fixation urinoir)**
- 3 - Arrivée d'eau G 1/2"**
- 4 - Alimentation électrique 24 V CC**

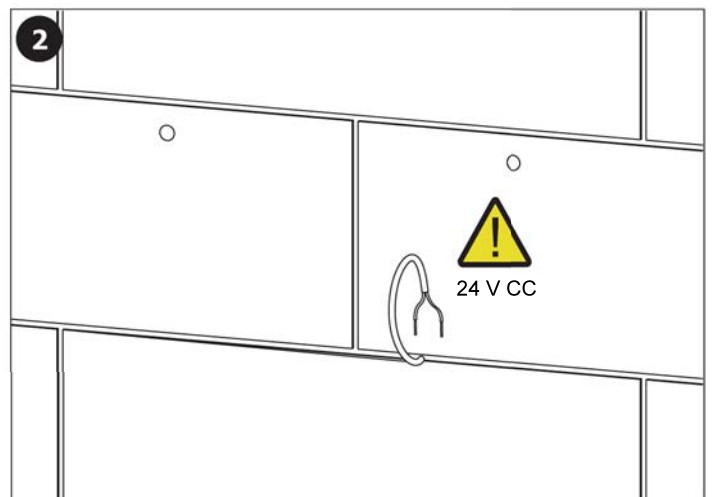
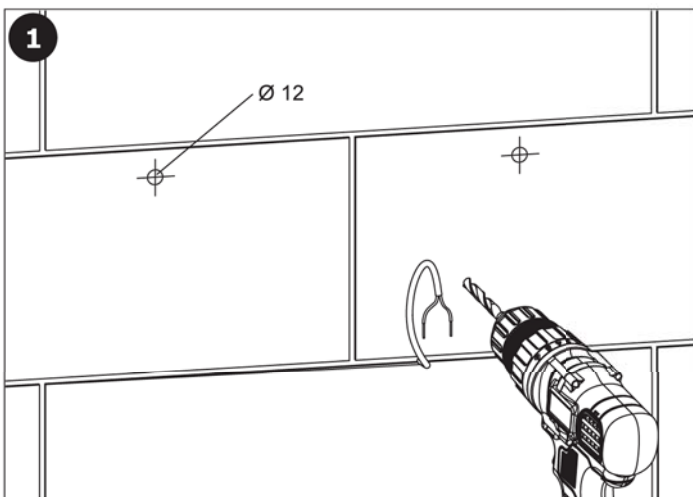

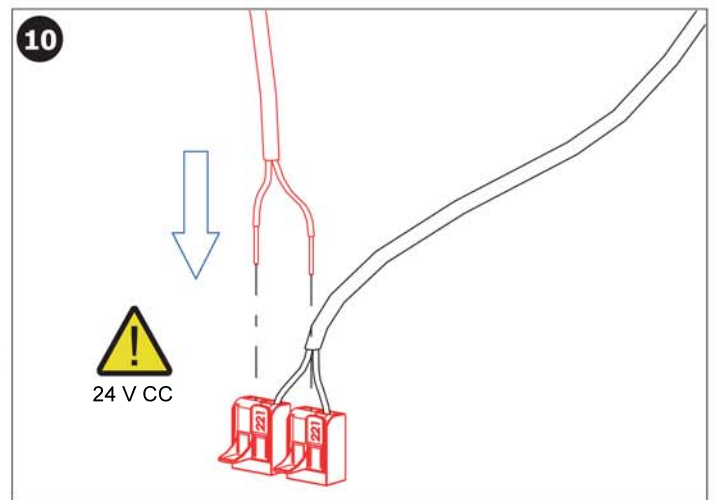
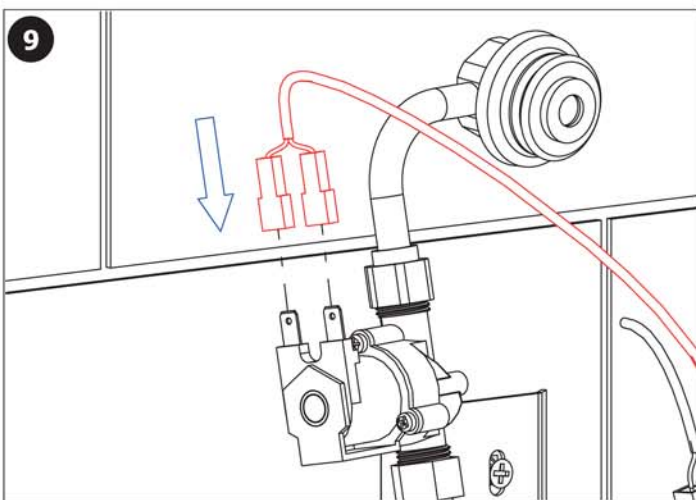
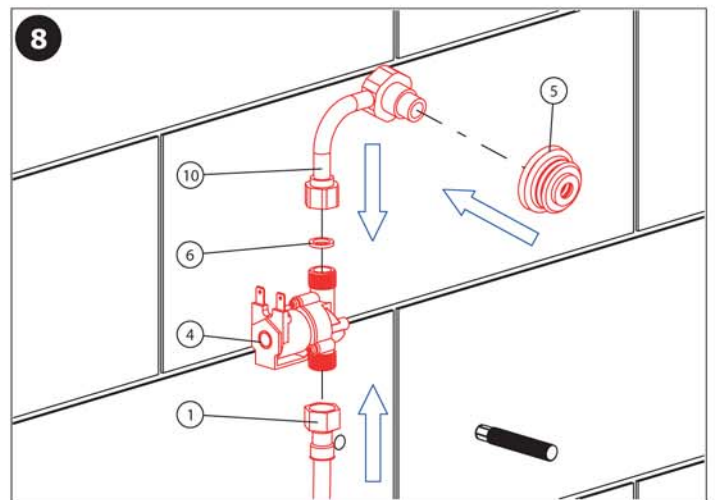
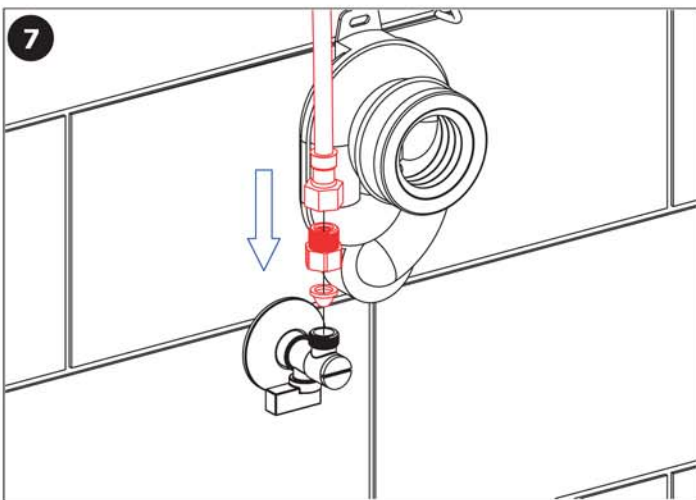
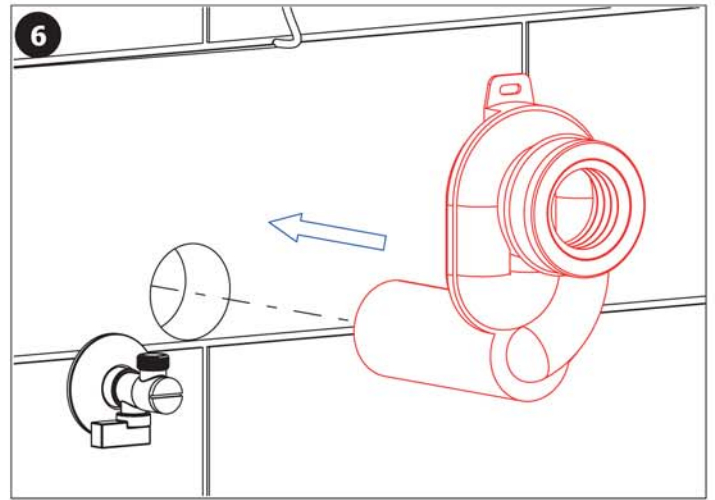
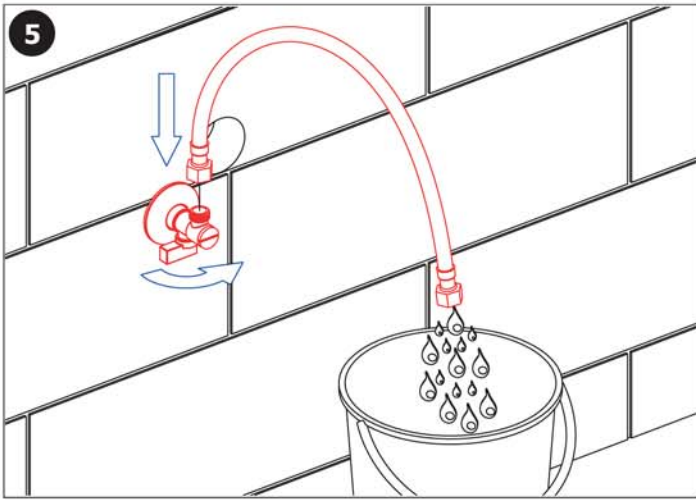
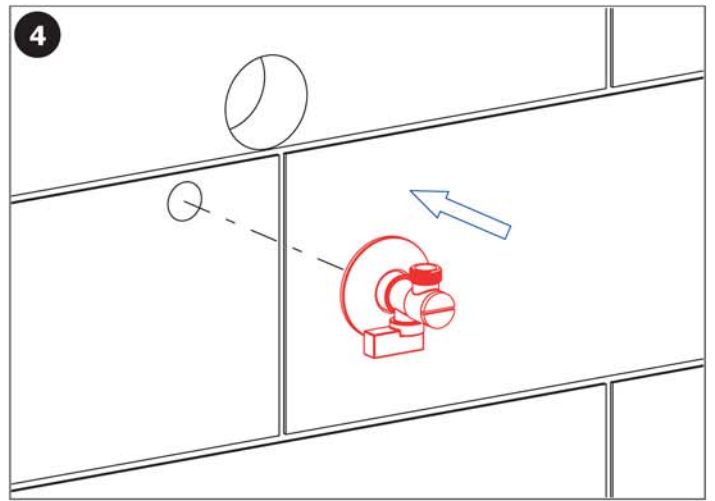
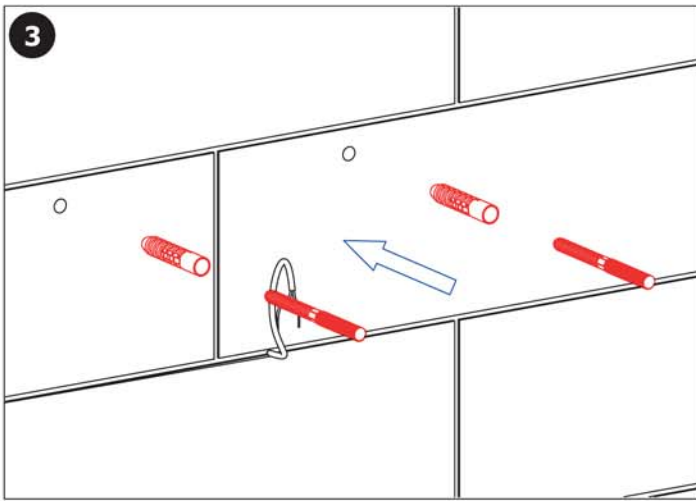

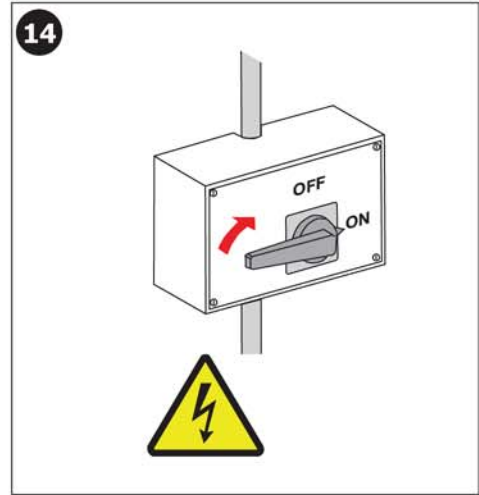
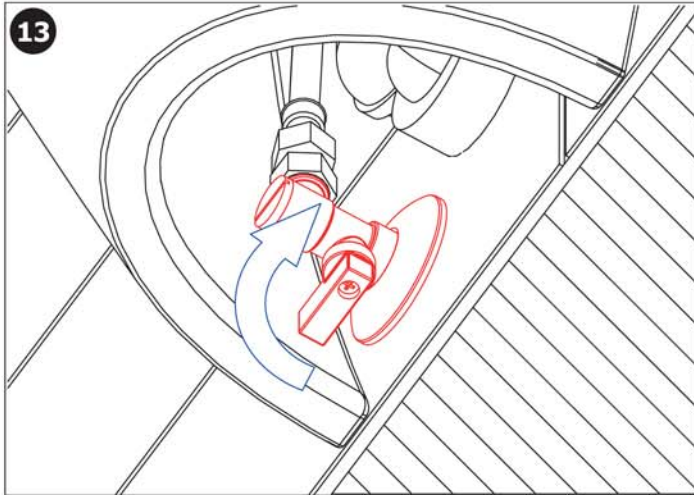
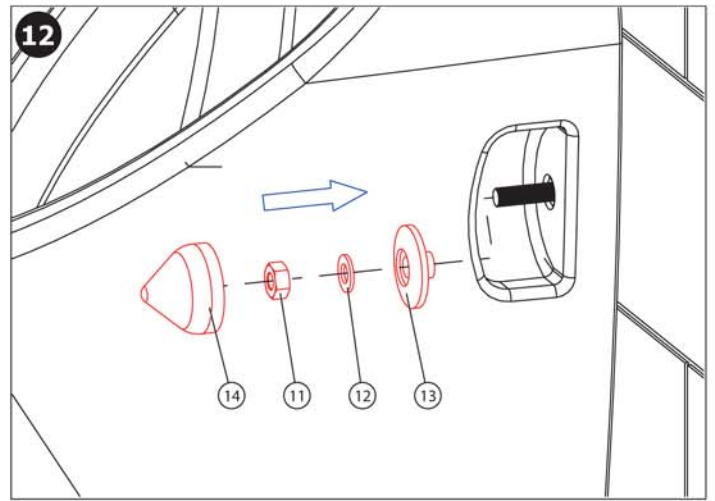
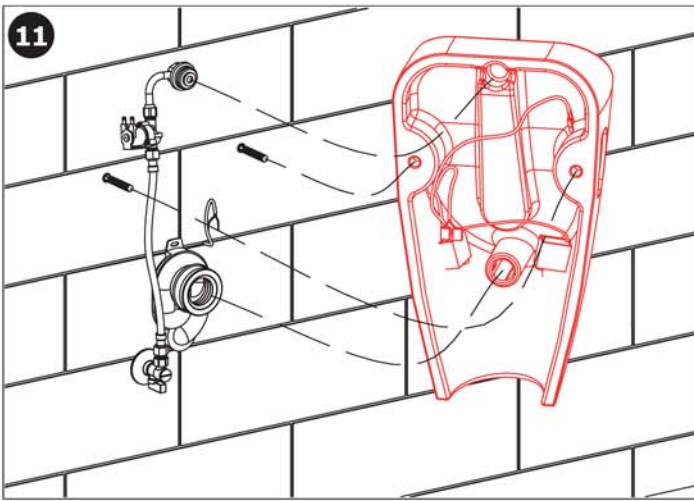

15

AJUSTEMENT AUTOMATIQUE

1x 1 min.

16

MODE AJUSTEMENT

20 min.

17

TEST min. 10 s.

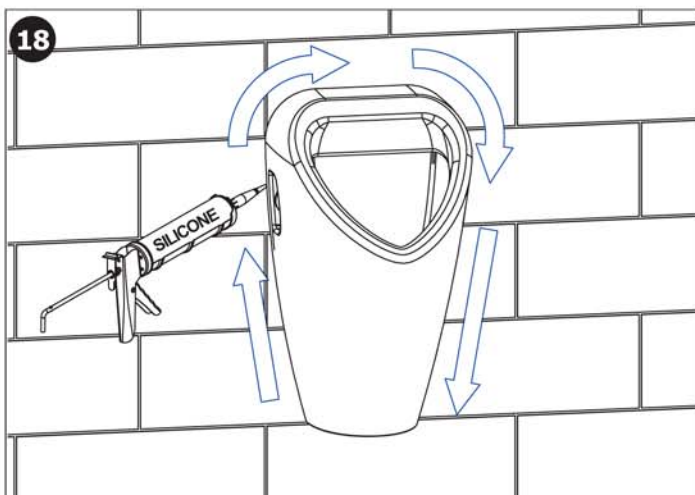

Service

Il est recommandé de vérifier le filtre de l'électrovanne une fois par an, afin de s'assurer que la membrane ne soit pas encrassée.

La vérification du serrage des vis et des surfaces de contact des connecteurs est également recommandée une fois par an.

Fabrication conforme aux normes 73/023/CEE et 89/336/CEE.

Accessoires recommandés

SLD04 : télécommande pour ajustement des paramètres

SLA26 : grille inox pour urinoir

DP-70 : écran urinoir parfum Apple Orchard

DP-71 : écran urinoir parfum Citrus Mango

DP-73 : écran urinoir parfum Cucumber Melon

DP-74 : écran urinoir parfum Ocean Spray