

## Automatic wall mounted tap AKWALINE

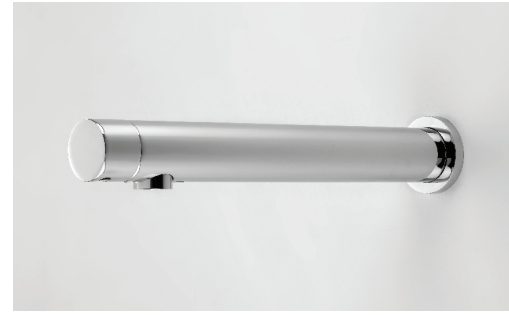

**Electronic wall mounted sink tap with nano infrared detection and Ø 28 mm extra-slim spout design, for cold or pre-mixed water.**

### Technical characteristics

- Self adjusting infrared sensor or settings by remote control (sensor range, flow time, hygiene rinse, temporary off, reset...).
- Power supply 9 V battery box or transformer 230/9V.
- **Double supply IP67 battery and transformer on recessed version. When installing on the mains, a backup battery is integrated for a normal operation in case of a power cut.**
- Sensor includes a low battery indicator light.
- Low energy consumption, battery lasts around 3 years.
- Security stop after 90 seconds without interruption.
- Solid brass construction.
- Flow rate 5 LPM (1,9 LPM on request).
- Operating pressure: 0.3 – 8.0 bars.
- Water temperature max. 70°C.
- Latching solenoid valve M1½" with filter.
- Limited warranty 3 years. CE.

### Orderin information

AKWALINE electronic tap

- RES-140** panel mounted, 9V battery
- RES-141** panel mounted, 9V transformer
- RES-142** recessed, 9V battery
- RES-143** recessed, 9V transformer

### Options :

- Remote control RES-31
- Long spout L version 275 mm.
- Matt black, matt gold finish (contact us)
- Brushed AISI 316 stainless steel body
- Limited flow rate 1,9 LPM
- 24 hours hygiene rinse
- IP 68 transformer to supply up to 4 faucets ref. RES-294
- Junction box to supply up to 10 faucets ref. RES-295
- IP68 transformer open wires RES-298.
- Matching soap dispenser design
- Integrated on washbasin wall support frame

**RES-143 recessed version, transformer**

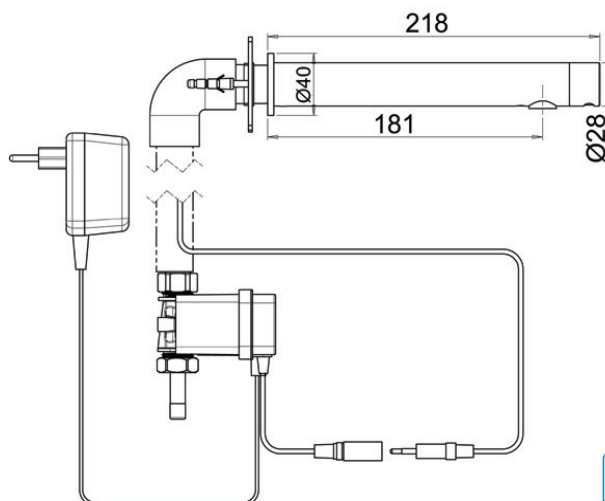

**RES-140 panel mounted version, battery**

